

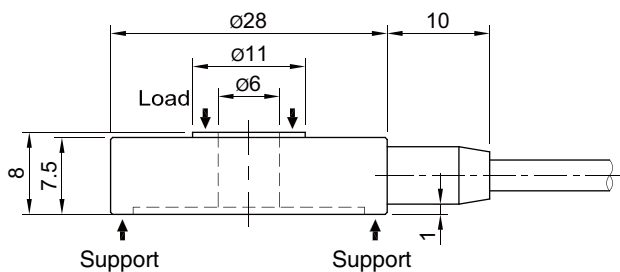

Model CFTL Series

Center hole type load cell
(20kg ~ 200kg)

- Low profile
- 17-4PH stainless steel

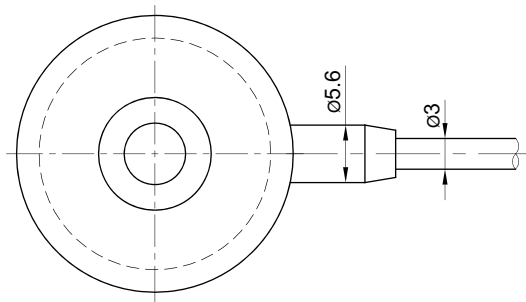

SPECIFICATIONS

MODEL	CFTL
Rated capacity (R.C.)	20, 50, 100, 200kg
Rated output(R.O.)	2.0mV/V(Approx.)
Material	Stainless steel (17-4PH)
Non-linearity	≤ 0.2% R.O.
Hysteresis	≤ 0.2% R.O.
Non-repeatability	≤ 0.2% R.O.
Creep error	≤ 0.2% in 20min.
Zero balance	≤ 1% R.O.
Compensated temperature range	-10 ~ 70°C
Operating temperature range	-20 ~ 80°C
Temp. effect on rated output	≤ 0.1% LOAD/10°C
Temp. effect on zero balance	≤ 0.1% R.O./10°C
Terminal input resistance	780 Ohms ± 30 Ohms
Terminal output resistance	700 Ohms ± 10 Ohms
Insulation resistance (Min.)	2000 MOhms at 50V DC
Excitation voltage	3~5V(Recommended), 10V(Max.)
Electrical connection	∅3mmx1.5m(28AWG x 4C Shielded)
Protection class	meets IP 64
Safe overload	150% R.C
Ultimate overload	300% R.C

ORDERING INFORMATION

CFTL - 100

MODEL	CAPACITY
CFTL	20, 50, 100, 200kg

WIRING INFORMATION

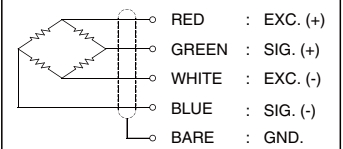

* Specifications are subject to change without notice

APR, 2020